

Arran LED Floodlight Luminaire

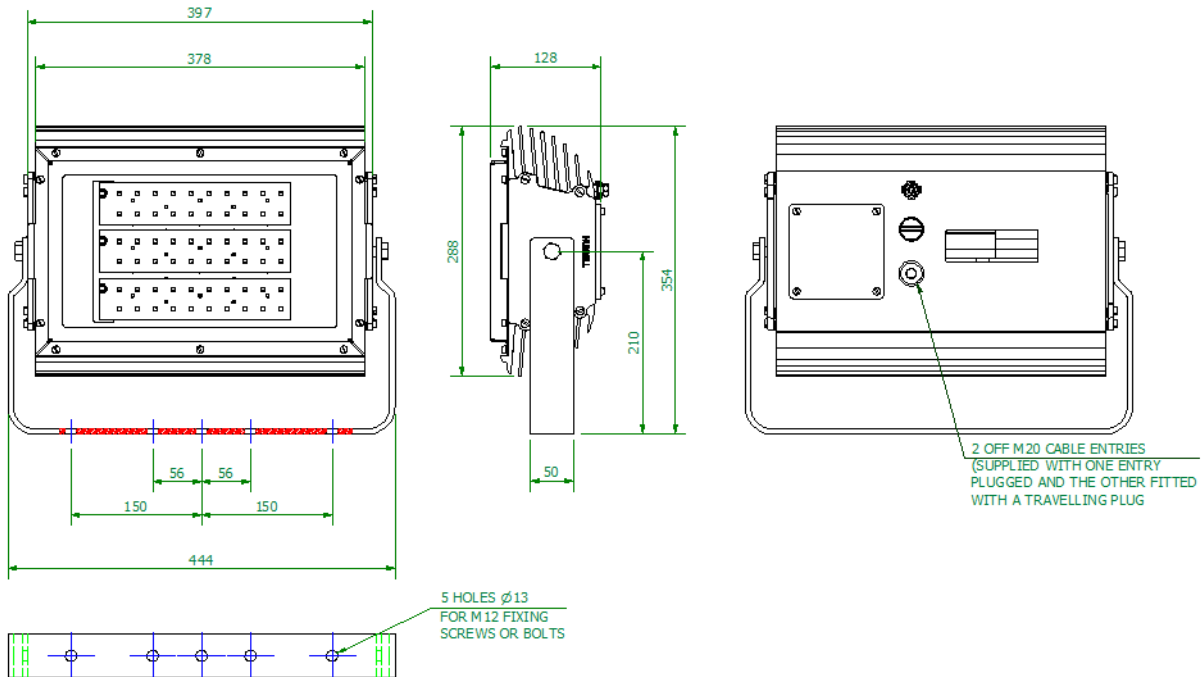

Industrial

INSTALLATION, OPERATION AND MAINTENANCE INSTRUCTIONS

Important: Please read these instructions carefully before installing or maintaining this equipment. Good electrical practices should be followed at all times and this data should be used as a guide only.





0.0 Specification	IOM – NEVIS-BULKHEAD Luminaire
Type of Protection	N/A
Standards	EN 60598-1,
Area Classification	Industrial, (Non- Hazardous)
Ambient	-50°C to +55°C
Ingress Protection	IP66 to EN 60529
Photobiological safety of Lamps and Lamp Systems	Risk Group 2 LED product to IEC 62471
Vision Advisory Claim	WARNING: Do not look at exposed led in operation especially with optical instruments. Eye injury can result.
 	<p>The CE marking of this product applies to "The Electrical Equipment (Safety) Regulations 2006", "The Electromagnetic Compatibility Regulations 2004", the "Waste Electrical and Electronic Equipment Regulations 2006". [This legislation is the equivalent in UK law of EU directives 2014/35/EU, 2014/30/EU, 2012/19/EU respectively].</p> <p>The UKCA marking of this product applies to "The Electrical Equipment (Safety) Regulations 2016", "The Electromagnetic Compatibility Regulations 2016", the "Waste Electrical and Electronic Equipment Regulations 2012</p> <p>M Poutney Technical Manager</p>

MEGOHM TEST - DUE TO THE SURGE PROTECTION PROVIDED IN THE LUMINAIRE TO PROTECT THE INTERNAL ELECTRONICS AND LEDs, A CIRCUIT WITH THE LED FIXTURE MAY GIVE A FALSE MEGOHMMETER (MEGGAR) READING. IF A MEGOHMMETER TEST IS REQUIRED, THE LED FIXTURE SHOULD BE REMOVED FROM THE CIRCUIT.

1.0 Introduction – ARRAN FLOODLIGHT

The Arran LED Floodlight Luminaire operates from mains voltage.

Power Factor >0.95 Power is constant over voltage range.

Table 1 MODEL VARIATIONS

CHALMIT MODEL NUMBER	WATTS	Hz	VOLTS	AMPS
ARRI/15L/LE/**	130	50/60	120-277	1.11 - 0.48A
ARRI/11L/LE/**	88	50/60	120-277	0.75 - 0.32A
ARRI/10L/LE/**	74	50/60	120-277	0.63 - 0.27A
ARRI/06L/LE/**	55	50/60	120-277	0.48 - 0.21A
ARRI/06L/LE/DC/**	55	-	105-250DC	0.6 - 0.3A

Ambient Range -50°C to +55°C

Tamb Storage -40°C to +50°C

Looping The looping current rating is 16A. 6mm² terminals are standard.

Fuse and MCB Ratings Current consumption, see table above. It is recommended that for selection of MCB's users should consult the MCB manufacturer. MCB ratings can vary depending on the



manufacturer and type and the size of the installation, i.e. impedance of conductors, however type 'C' breakers are usually suitable. The electronic control gear has an inrush current of 34A for less than 50µs. These figures are worst case with low resistance connections with short cables and low impedance supplies.

2.0 Storage

Luminaires should be stored in cool dry conditions preventing ingress of moisture and condensation.

3.0 Installation and Safety

3.1 General

There is no health hazards associated with this product whilst in normal use. However, care should be exercised during the following operations. Installation should be carried out in accordance with *IEE wiring regulations and any local authorised practices*. Any specific installation instructions must be referred to. In the UK the requirements of the *'Health and Safety at Work Act'* must be met. Handling and electrical work associated with this product to be in accordance with the *'Manual Handling Operations Regulations'* and *'Electricity at Work Regulations, 1989'*. Your attention is drawn to the paragraphs

- (i) 'Electrical Supplies',
- (ii) 'Electrical Fault Finding and Replacement' and
- (iii) 'Inspection and Maintenance'. The luminaires are Class 1 and should be effectively earthed.

The luminaires are quite heavy and suitable means of handling on installation must be provided.

Guard and Reflector can be supplied with or fitted retrospectively, the guard is to protect glass if there is a higher than normal risk of mechanical damage. The guard and reflector cannot be fitted together.

3.2 Tools

4mm A/F socket keys
4mm flat blade screwdriver
Suitable spanners for installing cable glands
Pliers, knife, wire strippers/cutters

3.3 Electrical Supplies

A maximum voltage variation of +6%/-6% on the nominal is expected.

3.4 Light Source

The luminaire is fitted with LEDS that can last 80,000 hours depending on ambient temperatures. Therefore depending on the functionality of the fitting replacement of LED's will be rare /unnecessary. If the LED assembly needs replaced refer to **4.2 LED Replacement**.

3.5 Mounting

Luminaires should be installed where access for maintenance is practical and in accordance with any lighting design information provided for the installation. This will usually consist of aiming points and aiming angles. Mounting arrangements should be secured with lock washers or self-locking nuts and bolts.

3.6 Cabling and Cable Glands

3.6.1 Cable

The maximum conductor size is 6mm². Internal earth point is provided next to the main terminal block. 300/500V cable ratings are adequate and no special internal construction is necessary. The standard looping cable size is up to 6mm². Terminals are supplied with suitability for looping. Where looping is used the maximum current is 16A. Terminals are accessed by removing the access door cover on the back of the luminaire. Maximum cable temperature rise is 20°C above ambient. The cable connections are made by removing the access door cover on the back of luminaire. Loosen and remove all but one of the access door captive screws. Rotate access door to allow for entry into fixture. The retaining screws are captive and should be re-greased as required. The conductors should be bared back so that they make full contact in the terminals, but the bare conductor should not be more than 1mm beyond the terminal. Unused terminal screws should be tightened. The core must be identified by polarity and connected in accordance with the terminal markings. Before re-fitting the cover, a final check on the correctness of connections should be made. Cover bolt torque 2 Nm.

3.6.2 Cable Glands

The installer and user must take responsibility for the selection of cables, cable glands and seals. Cable glands and sealing plugs when installed must reliably maintain the IP rating of the enclosure IP66. Sealing plugs are provided and a tool must be used for their removal. Where brass cable glands are used in a corrosive environment, cadmium or nickel plating should be used. Two tapped cable entries are provided, one with a plug and seal suitable for permanent use, the other has a travelling plug. M20 entries are standard, other sizes are available on request up to M25.

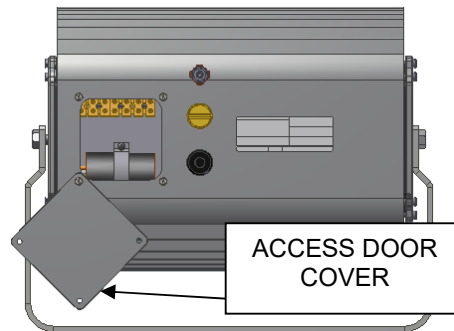

4.0 Inspection and Maintenance

Visual inspection should be carried out at a minimum of 12 monthly intervals and more frequently if conditions are severe.

Maximum Insulation Resistance Test 500V dc.

- 1 Check if any LED's have failed (not lit).
- 2 The LEDs are mounted on boards, if there is 3 or more LED's not working on one board the light output will have dropped to a level where the LED board may need replaced. Refer to **4.2 LED Replacement**.
- 3 Check for mechanical damage/corrosion.
- 4 Check for loose connections including earthing.
- 5 Check for undue accumulations of dust or dirt.
- 6 Verification of tightness of fixing, glands, blanking plugs etc.
- 7 Check for unauthorised modifications.
- 8 Check condition of enclosure gaskets and fastenings.
- 9 Check for any accumulation of moisture.
- 10 Clean the lamp glass.
- 11 Check that mountings are secure.
- 12 If there is suspicion that the luminaire has suffered mechanical damage, a stringent workshop check should be made.

Important: *Where spares are needed, these must be replaced with manufacturer parts. No modifications should be made without the knowledge and approval of the manufacturer.*

4.1 Electrical Fault Finding and Replacement

Any fault finding must be done by a competent electrician with the luminaire isolated and if carried out with the luminaire in place, under a permit to work. Fault finding is by substitution with known good components.

4.2 LED Replacement.

The need and frequency of replacing LED's be dependent on the functionality of the fitting. If it is continually running at high ambient temperatures it will affect the frequency of LED replacement. If it is necessary to replace the LED's, the LED's are mounted on boards that can be replaced individually. (The boards with LED's supplied by Chalmit). Remove cover assembly.



Removal of LED assembly is as follows:

1. Unscrew 5 off screws that secure the board to the casting.
2. Carefully lift the plate and disconnect push in connector.

Replacement of LED assembly is the reverse of the removal.

Replace Front cover and fully tighten all bolts.

5.0 Disposal of Material

The unit is mostly made from incombustible materials. The control gear contains electronic components and synthetic resin. All these may give off noxious fumes if incinerated. Care must be taken to render these fumes harmless and avoid inhalation. Any local regulations concerning disposal must be complied with. Any disposal must satisfy the requirements of the WEEE directive [2012/19/EU and Regulations 2012] and therefore must not be treated as commercial waste.



To comply with the Waste Electrical and Electronic Equipment directive 2012/19/EU and Regulations 2012 the apparatus cannot be classified as commercial waste and as such must be disposed of or recycled in such a manner as to reduce the environmental impact.

Directions for Installation of Accessories

Note: Reflector and Guard cannot be used simultaneously.

WARNING: Ensure the supply circuit is off before starting installation.

To install reflector, carefully remove the 7 screws provided in housing that align with the locations of the holes on the reflector and retain the screws. Place the reflector into position, lining up the holes in the reflector with the holes on the lens housing. Reinstall the removed 7 screws into the existing hole location, and tighten to secure. CAUTION - All screws must be properly installed to maintain the integrity of the lens gasket seal.

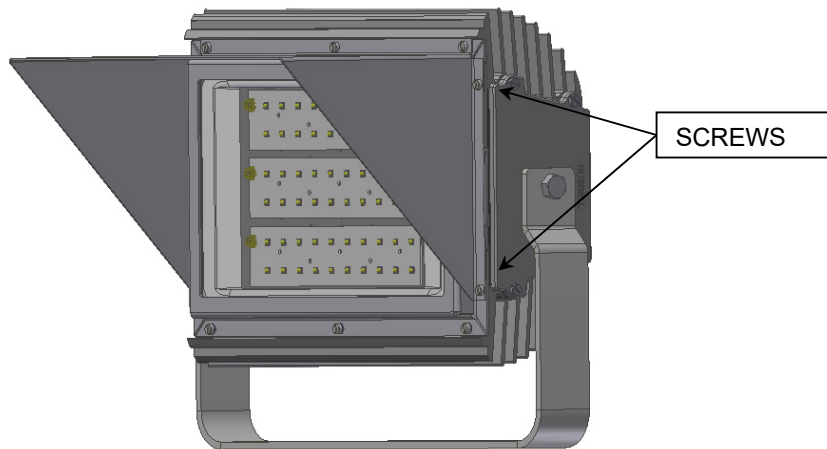

To install lens assembly guard, verify that the luminaire is completely assembled. Install lens guard on lens assembly by hooking the guard's end tabs under the luminaire housing's end tabs. Verify a tight attachment.

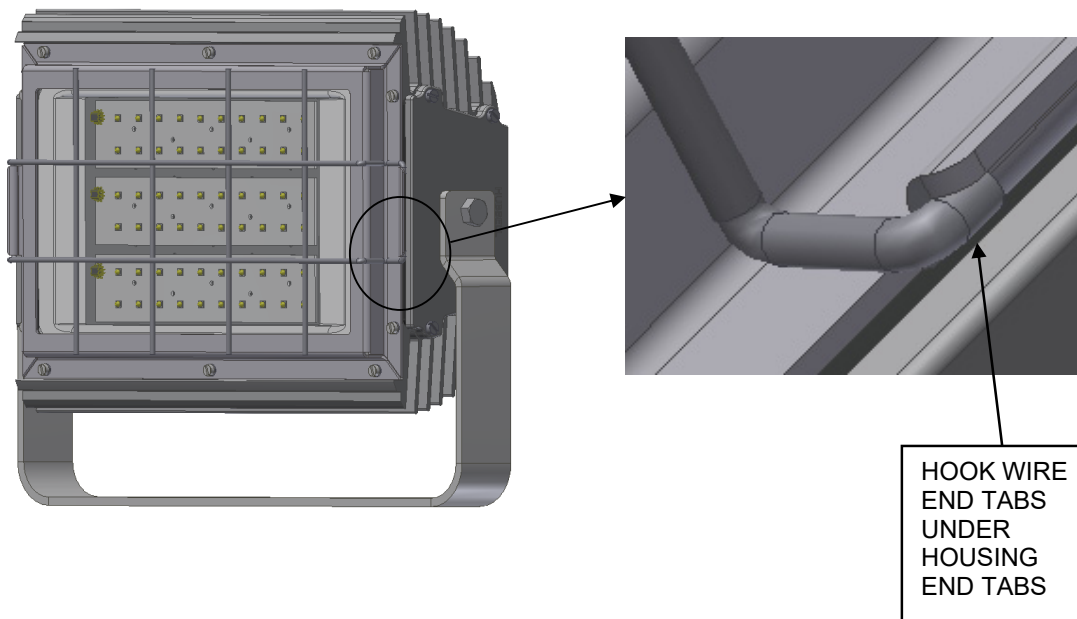



Chalmit Lighting is a leading supplier of Hazardous Area lighting products

	CHALMIT LIGHTING PO Box 5575 Glasgow, G52 9AP Scotland	
Telephone: +44 (0) 141 882 5555 Fax: +44 (0) 141 883 3704 Email: info@chalmit.com Web: www.chalmit.com	Registered No: 669157 Registered Office: Cannon Place 78 Cannon Street London EC4N 6AF UK	

For technical support, please contact: techsupport@chalmit.com

Note: Chalmit Lighting reserves the right to amend characteristics of our products and all data is for guidance only.



	EU/UK-Declaration of conformity		
	UE-Déclaration de conformité		
	EU-Konformitätserklärung		
Manufacturer	Chalmit	Address	388 Hillington Road, Glasgow. G52 4BL Scotland UK
Product	Arran LED Floodlight Industrial		
Catalogue	ARRI/15L/LE/** see Table 1		
Area Classification	Industrial, (Non- Hazardous)		
Ingress Protection	IP66		
Ambient	-50°C to +55°C		
Terms of the directive:		Standard & Date Certified to	Standards Date Declared to
2014/30/EU Regulations 2016		Electromagnetic compatibility	EN 55015 : 2019
2014/30/UE		Compatibilité électromagnétique	EN 61547 : 2009
2014/30/EU		Elektromagnetische Verträglichkeit	EN 61000-3-2 : 2019
2014/35/EU Regulations 2016		Low voltage equipment	EN 60598-1 : 2015
2014/35/UE		Équipements électriques à bas voltage	EN 60598-2-5 : 2015
2014/35/EU		Niederspannungsgeräte / -systeme	EN 60529 : 1992+A2:2013
2012/19/EU Regulations 2012		Waste of electrical and electronic equipment	
2012/19/UE		Déchets d'équipements électriques et électroniques	
2012/19/EU		Entsorgung der elektrischen und elektronischen Geräte / Systeme	
2011/65/EU Regulations 2012		RoHS II Directive	

On behalf of the Chalmit, I declare that, on the date the equipment accompanied by this declaration is placed on the market, the equipment conforms to all technical and regulatory requirements of the above listed directives.

En tant que représentant du fabricant Chalmit, je déclare qu'à la date où les équipements accompagnant cette déclaration sont mis sur le marché, ceux-ci sont conformes à toutes les dispositions réglementaires et techniques des directives énumérées ci-dessus.

Hiermit bestätige ich, im Namen von Chalmit, dass am Tag der Lieferung des Produkts/der Produkte zusammen mit dieser Erklärung das Gerät/die Geräte alle technischen und regulativen Anforderungen der oben aufgeführten Direktiven erfüllt.

Name and Date Mark Poutney 19/05/2021
 Nom et Date
 Name und Datum

Technical Manager
 Directeur technique
 Technischer Leiter

Quality Management System Accreditation:
 Système de Management Qualité Accréditation:
 Qualitätsmanagementsystem Akkreditierung:
 Environmental Management System.
 Système de gestion de l'environnement.
 Umwelt kontroll system.
 Certificate No./Certificat N°/Zertifikat Nr.

ISO 9001

ISO 14001
 by/par/durch
 Lloyd's Register
 LRQ 4005876